



MODEL #: 190810

INSTRUCTION MANUAL



SMITH® SB80SL Fertilizer and Salt Spreader
(190810)

Do not return this product to the store.
For help, information, or parts contact:



Craftsmanship. Innovation. Commitment

www.thefountainheadgroup.com

(800) 311-9903 | info@thefgi.com

23 Garden St. New York Mills, NY, 13417



WARNING

Read and fully understand manual
before using this product.

Failure to follow instructions could
result in death or serious injury.

CONTENTS

IMPORTANT SAFETY INSTRUCTIONS	3
WHATS IN THE BOX - PARTS FOR ASSEMBLY	4
ASSEMBLING YOUR SMITH® SB80SL	6
CALIBRATION AND FINAL ASSEMBLY	8
HOW TO REPLACE SMITH® SB80SL MATERIAL PLATES.....	9
HOW TO ADJUST THE SMITH® SB80SL MATERIAL PLATES	11
HOW TO USE THE SMITH® SB80SL	12
SMITH® SB80SL SPARE PARTS	14
SMITH® SB80SL SPARE PARTS MODELS	15
WARRANTY STATEMENT.....	16

IMPORTANT SAFETY INSTRUCTIONS

- Read and understand the entire instruction manual before using this spreader.
- Follow all instructions and precautions in the instruction manual when using this spreader.

▲ WARNING: RISK OF PERSONAL INJURY DUE TO CONTACT WITH ROTATING COMPONENTS.

- Keep hands and feet away from wheels, belts, and pulleys when spreader is in motion.
- Never modify or alter the spreader from original condition.
- Use only replacement parts from original manufacturer. Other replacement parts are not compatible with this spreader.

▲ WARNING: RISK OF PERSONAL INJURY AND/OR PROPERTY DAMAGE DUE TO CHEMICAL EXPOSURE.

- Read and follow all instructions and precautions on chemical manufacturer's label of chemicals used in this spreader.
- Use only chemicals indicated for broadcast spreading applications. Some chemicals may create a toxic or other hazardous conditions when broadcast spread.
- Always refer to chemical manufacturer's instructions and/or the chemical Safety Data Sheet (SDS) for proper mixture and safe application.
- Use the appropriate Personal Protective Equipment (PPE) as recommended by the chemical manufacturer and/or refer to the chemical Safety Data Sheet (SDS) of the chemical being used. This includes at least goggles, gloves, and protective clothing. Failure to use appropriate PPE could result in chemical exposure through skin contact, eye contact, inhalation, or other means.
- Keep the spreader and all chemicals out of the reach of children and pets.
- Never store chemicals in the spreader.
- Store or dispose of any unused chemicals as instructed by the chemical manufacturer due to the potential for environmental damage from a spill or leak, and/or refer to the disposal criteria referenced in the SDS.
- Clean spreader after each use to avoid unintended chemical exposure and prevent contamination of subsequent applications.

▲ WARNING: RISK OF ENVIRONMENTAL CONTAMINATION AND HARM TO AQUATIC LIFE.

- Follow all local regulations for broadcast applications of fertilizers and other chemicals.
- Avoid overapplication, which can lead to nutrient runoff.
- Maintain buffer zones around bodies of water.
- Use the deflector shield along the boundaries of the application area to prevent broadcasting chemical onto roads, sidewalks, driveways, gutters, storm drains, or other non-targeted areas where the chemical could wash away.

SAVE THESE INSTRUCTIONS FOR FUTURE USE.

WHATS IN THE BOX - PARTS FOR ASSEMBLY

SMITH® SB80SL Spare Parts -

Item	Description
A	Hopper Body & Frame
B	Pneumatic Wheels
C	Control Rod
D	Loop Handle
E	Mesh Grill
F	Mesh Grill Lock
G	Back Stand
H	4 x M6 x 45 bolts
J	4 x M6 lock nuts
K	Small Cotter Pin
L	Large Cotter Pin
M	Pivot Bracket
N	4 x M6 x 65 bolts
O	4 x M6 lock nuts
P	Summer Material Plate
Q	Winter Material Plate

NOTICE: Empty all contents of the box into a flat surface and count parts to make sure they are all there.

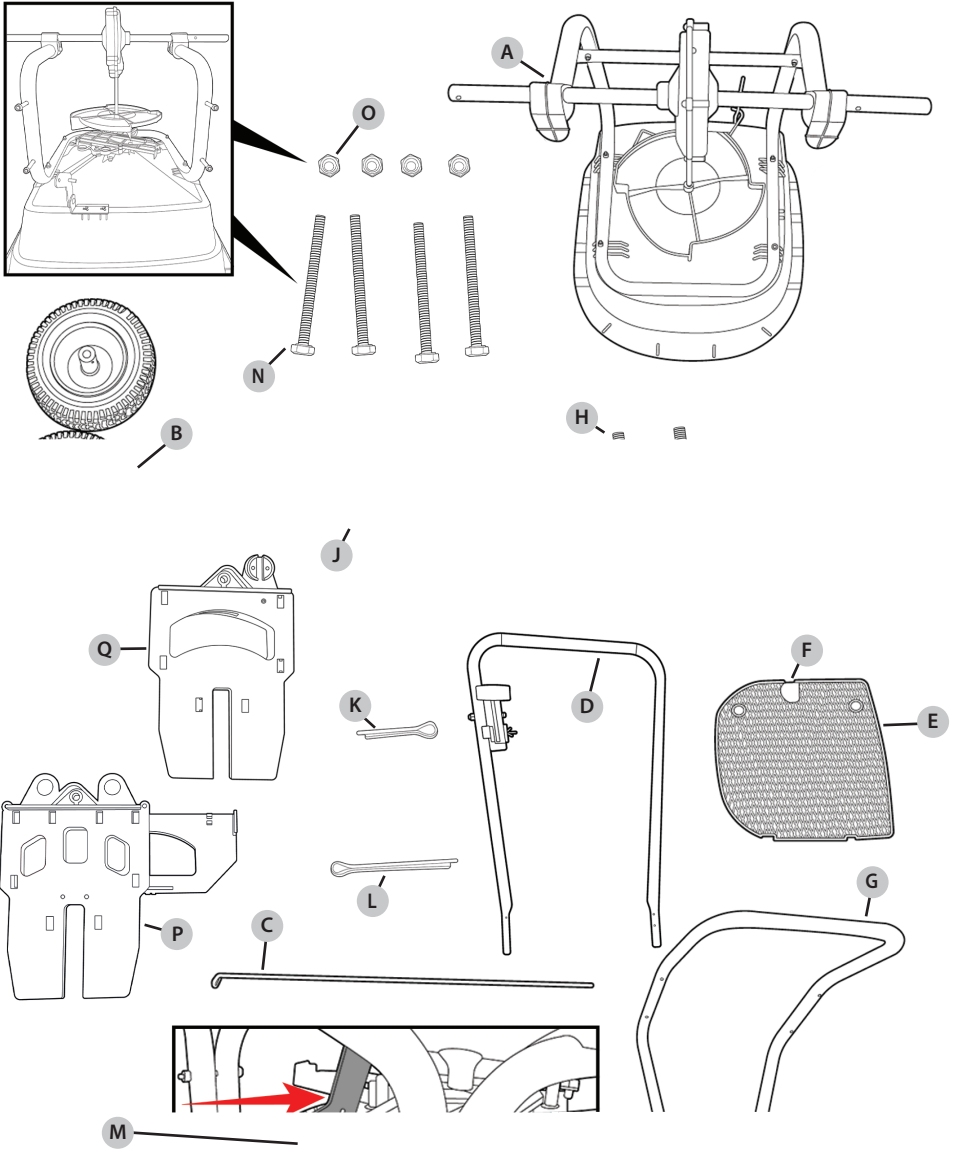

ASSEMBLING YOUR SMITH® SB80SL

1. Place the Hopper body (A) on the table so that the gearbox is pointing upwards. Take the bolts out of the main frame (A) - you will use these to attach the back stand to the hopper body and main frame (A). Remove the nuts from the bolt ends.

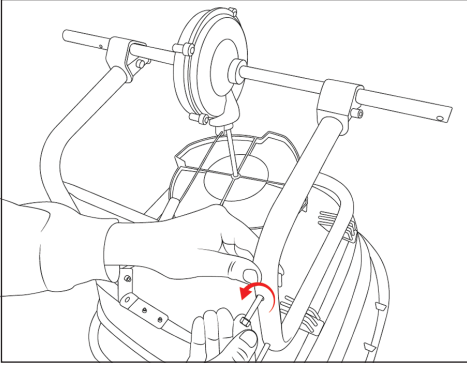

2. Take the back stand (G) and align it with the holes on the main frame (A). Place the four bolts through the holes available.

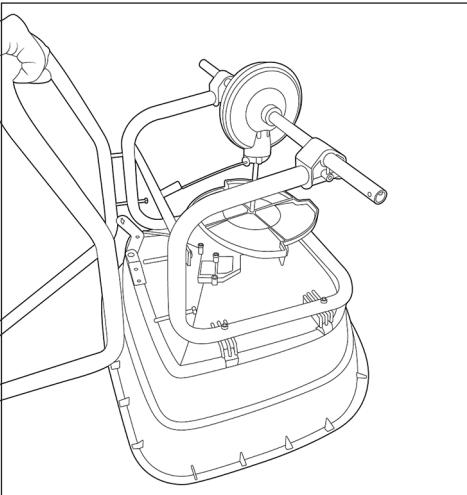

3. Use a wrench to tighten the lock nuts. The back stand (G) should now be securely attached to the hopper body and frame (A).

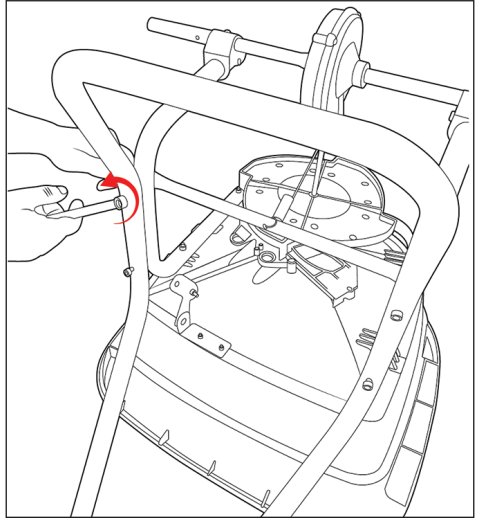

4. Take the pneumatic wheels (B) and slide them over the axles on each side of the main frame (1). You will also need the two cotter pins (K & L) that sit inside the parts bag.

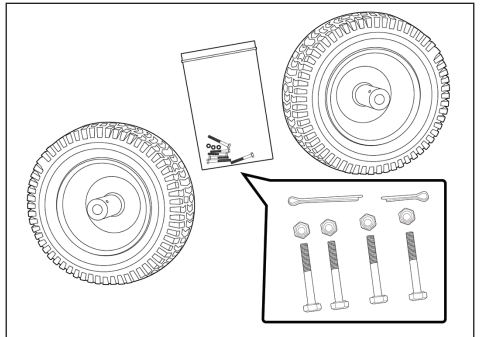

5. Align the hole on the inside of the pneumatic wheel (B) with the hole on the axle. Take the large cotter pin (L) and thread it through the two holes.

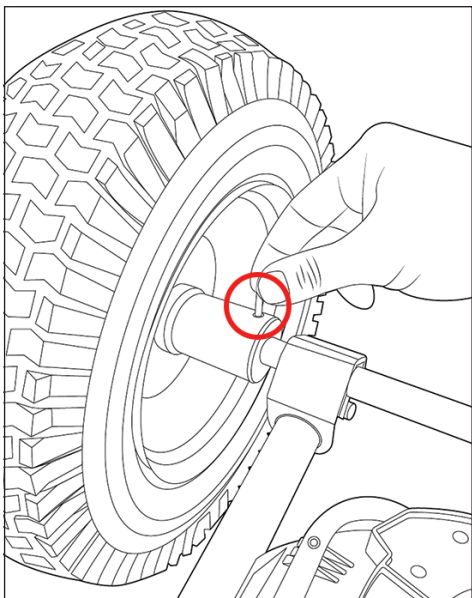

6. After threading the cotter pin (L) through the two holes, use a pair of pliers to pull apart the two ends of the cotter pin (L). The wheel will then be secured in place..

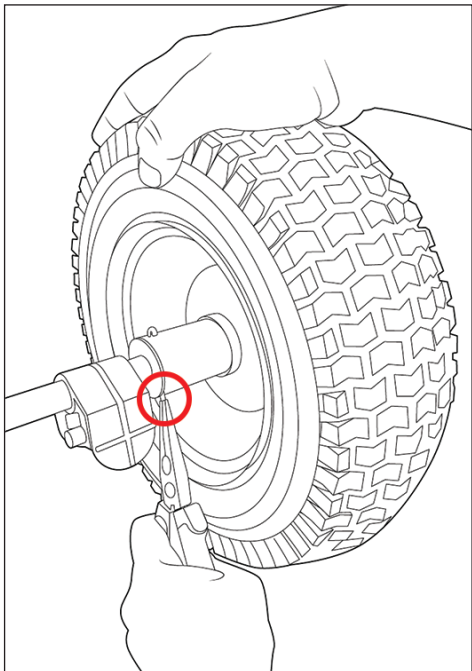

7. Take the small cotter pin (K) and place it through the hole on the outside of the other wheel.

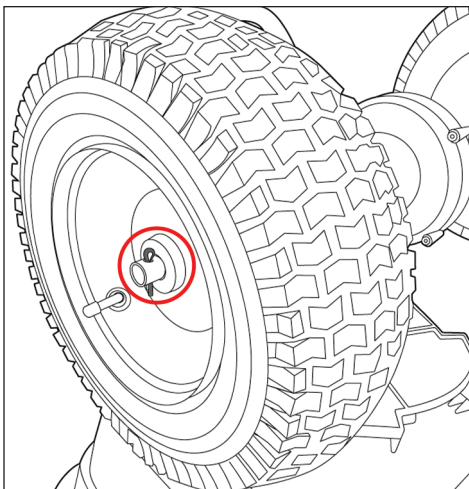

8. Once in position, use the same pliers to split the ends of the cotter pin (K) to hold the wheel in place.

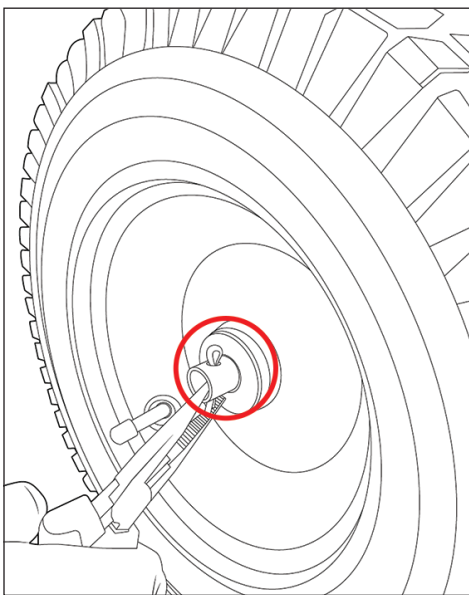

9. Turn the hopper body and main frame (A) over so that the spreader sits on its wheels and back stand. Take the handle bar (D) and slide it down the two ends of the back stand.

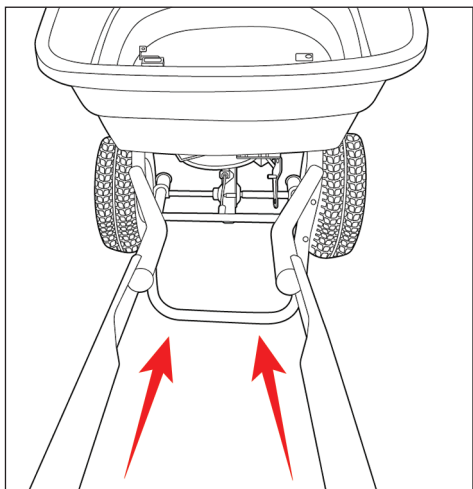

10. Align the holes on the handle bar (D) and on the back stand (G).

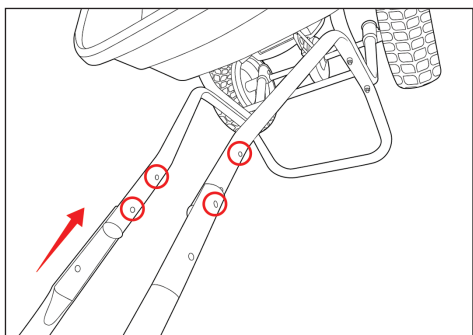

11. Thread the four remaining bolts (H) through the holes on the handle bar (D) and the back stand (G).

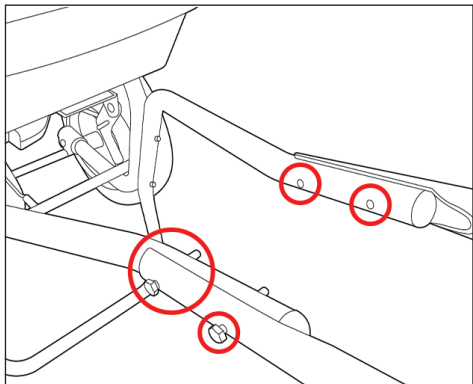

12. Take the bent end of the control rod (C) and thread it through the hole at the back of the pivot bracket (M). It should lock into place.

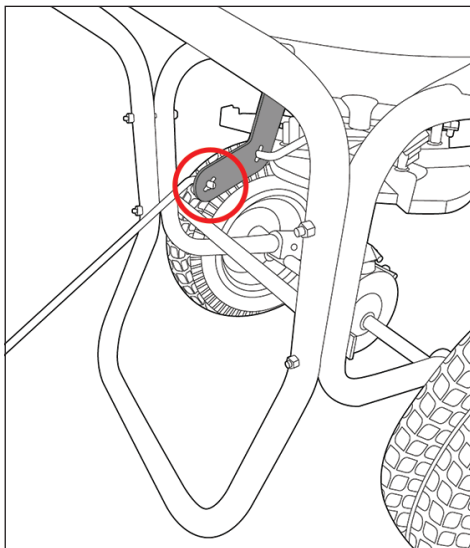

CALIBRATION AND FINAL ASSEMBLY

13. Take the other end of the control rod (C) and align it with the hole on the on/off mechanism of the loop handle (D). Push the on/off lever all the way to 20 and then hand tighten the screw.

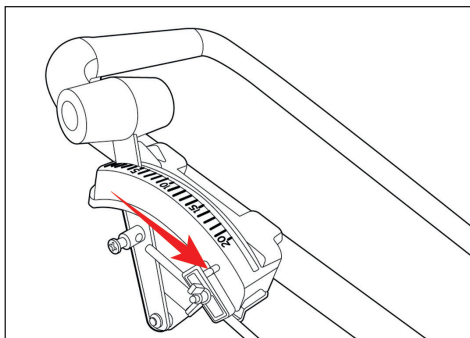

14. Make sure the slider at the bottom of the hopper is fully open. You should see the entirety of the holes or hole on the slide system.

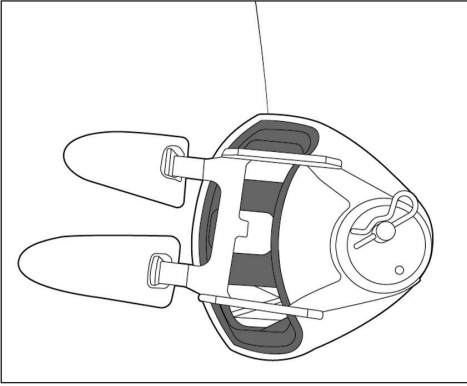

15. If the application hole is fully open and the lever is set at 20, tighten the Hex screw so that the control rod (C) is secure. You are now correctly calibrated.

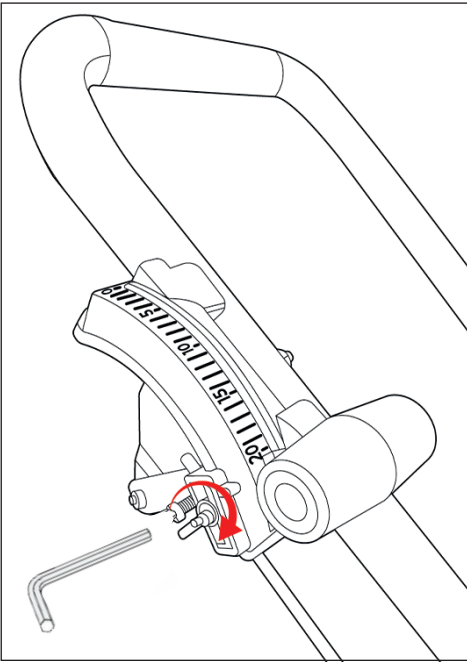

HOW TO REPLACE SMITH® SB80SL MATERIAL PLATES

1. Place the finished unit onto a table so that the back of the spreader is easily accessible.

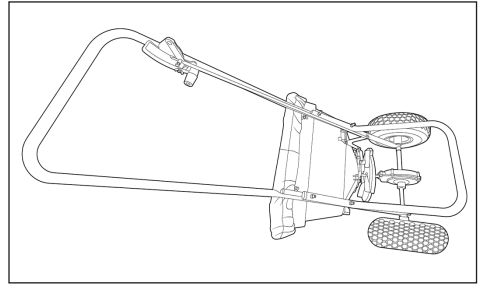

2. Locate the R-pin that helps hold the material plate in place on the underside of the material plate. Remove the R-pin.

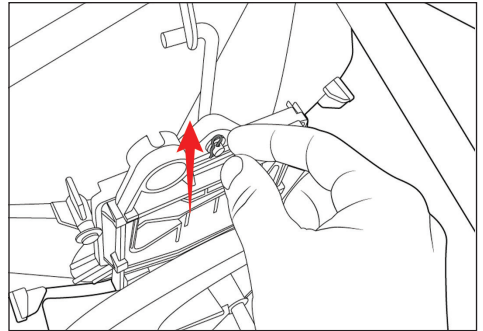

3. Push the top of the pivot bracket so the material plate is pushed back and the pivot rod is loosened.

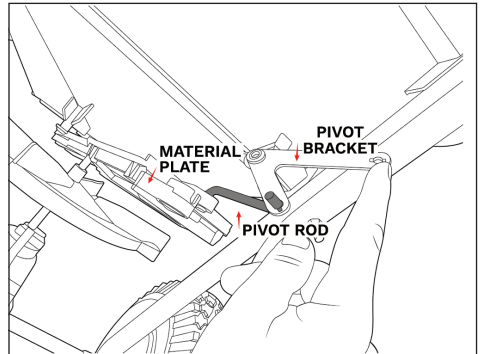

4. Remove the pivot rod by pushing the tip through the hole at the top of the material plate. When the pivot rod is removed, remove the material plate.

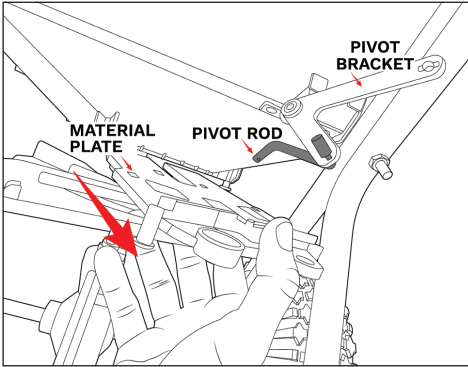

5. When you have removed the material plate you no longer wish to use, find the alternative material plate and push it into the grooves on the bottom of the hopper.

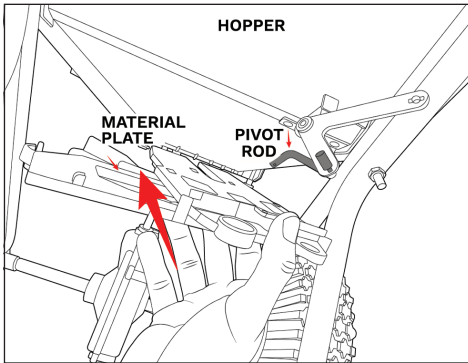

6. The material plate should be secure and sit level underneath the hopper. It should slide smoothly in and out of the grooves.

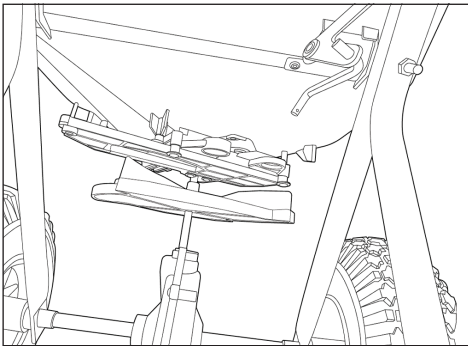

7. Pull the material plate out slightly to allow space to insert the pivot rod back into the pivot bracket and material plate.

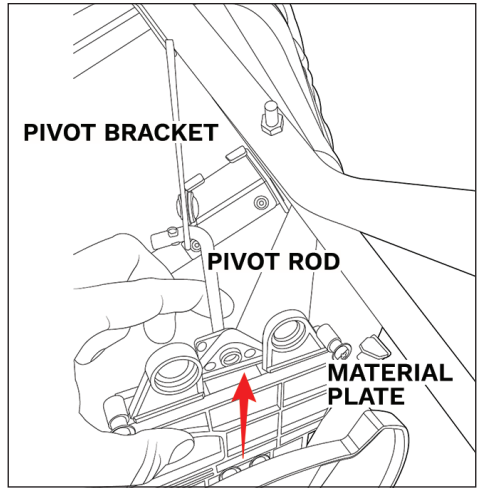

8. Push the bottom end of the pivot rod into the hole at the top of the material plate and secure with the R-pin.

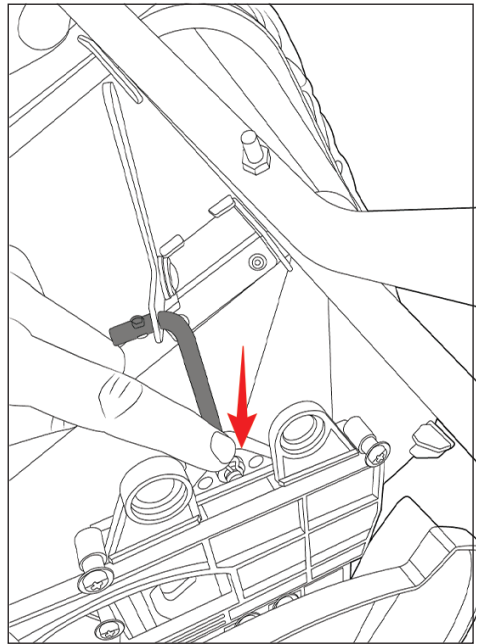

HOW TO ADJUST THE SMITH® SB80SL MATERIAL PLATES

The SMITH® SB80SL includes both a Summer Fertilizer & Seed as well as an Ice Melt & Salt material plates. These plates are specifically engineered to control the material flow and application of the materials, ensuring the correct and even application as determined by the material being spread. The Slider Adjusters included on the Summer Fertilizer & Seed plate are used to balance the spread pattern by restricting the flow of material from the hopper on either side.

Different materials will spread differently, and these adjusters will help even your spread pattern. See the following page for details.

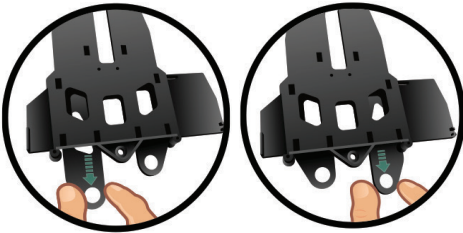

Left hand slider adjuster

Right hand slider adjuster

LHS (Left hand slider adjuster) is recommended to be engaged when spreading large sized granular materials to provide a more uniform distribution on the left and right side of the spread pattern.

RHS (Right hand slider adjuster), is used with very light materials (e.g. grass seed). Engaging the RHS (Right hand slider adjuster) will help balance the spread pattern and application for light materials.

▲ WARNING: The manufacturer cannot be held responsible for any variations in area application volumes, or spread width difference, due to possible variations in materials, application conditions at the time and different operator application techniques.

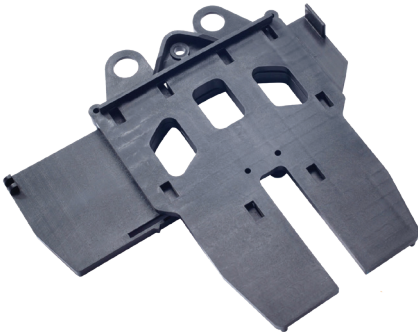

Summer Fertilizer & Seed plate

▲ WARNING: Do not spread Fertilizer or Seed materials with the orange-colored single-hole Ice Melt & Salt material plate.

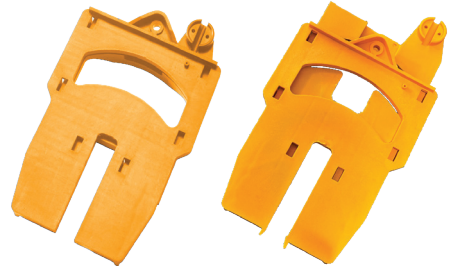

Ice Melt & Salt plate

Sidewalk slider engaged for reduced spread width on right

NOTICE: The manufacturer cannot be held responsible for any variations in area application volumes, or spread width difference, due to possible variations in materials, application conditions at the time and different operator application techniques.

▲ WARNING: Do not spread Fertilizer or Seed materials with the orange-colored single-hole Ice Melt & Salt material plate.

HOW TO USE THE SMITH® SB80SL

Walking Patterns for the optimum application (For Fertilizer Only)

There are two methods of effective spreading, Full Rate (Single Pass over the area at the setting for the full amount) and Half Rate (Double pass over the area in a crossing pattern at 50% of the full amount - details below).

Make sure that you walk at a steady pace of 3mph holding the spreader stable, not tipping forward or back as this will affect your application.

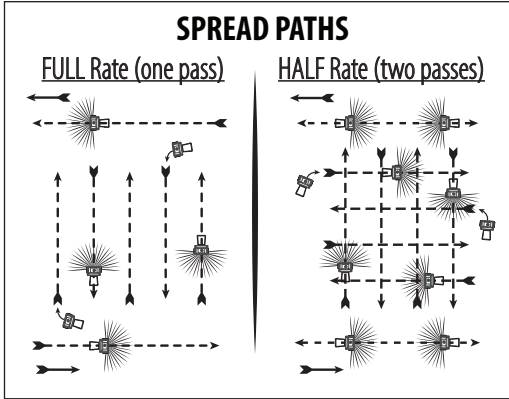

Full Rate - one pass

Cover the area as shown making the next pass at the edge of your spread pattern or where the fertilizer thrown begins to feather.

HALF Rate - 2 passes

Use ½ the application rate (lbs. per 1,000) suggested on the back of your fertilizer bag. You cover the area using the cross path method.

Half rate is defined by reducing the pounds per thousand square feet by 50%. This does NOT correlate to a 50% reduction on the gauge indicator. Refer to the chart below for the proper half rate setting.

Rate Setting Guide

Grams/SQ Meter	Lbs. Per 1,000SF	SMITH®	Scotts®	EarthWay®	LESCO®
10	2	9	3	13	5
15	3	10	3.5	14	6
20	4	12	4.5	16	8
25	5	13	5.5	17	9.5
30	6	13.5	6	18	10
35	7	14	7	19	10.5
40	8	15	8	20	11
45	9	16	9	22	13
50	10	20	10	23	14

NOTICE: Review the coverage and weight of the bag to help determine the correct setting.

For a 25 lb. bag that covers 5,000 Square Feet (SF), the calculation is $25/5 = 5$ lbs. per 1,000 Square Feet, a setting of 13. HALF Rate would be 1/2 of the 5 lbs. rate (2.5 lbs.) or a Setting of 9





















TWO SEASONS.
ONE SPREADER.



SLIDE-SYSTEM
TECHNOLOGY
SETTINGS











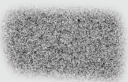



PRODUCT	SUMMER Shut-Off	SLIDER ADJUSTER SETTINGS
---------	-----------------	--------------------------

	POWDERED OR MICRO GRANULAR FERTILIZER	 NO ADJUSTMENT OF EITHER SLIDER RECOMMENDED 
	MEDIUM GRANULAR FERTILIZER	 NO ADJUSTMENT OF EITHER SLIDER RECOMMENDED 
	LARGE GRANULAR FERTILIZER	 ADJUSTMENT OF THE LEFT SLIDER RECOMMENDED 6-7 CLICKS 
	GRASS SEED OR VERY LIGHT MATERIALS	 ADJUSTMENT OF THE RIGHT SLIDER RECOMMENDED 3-4 CLICKS 
	PELLETED MATERIALS	 ADJUSTMENT OF THE LEFT SLIDER RECOMMENDED (SELECT CLOSED) 
	LARGE GRANULAR ICE MELTS	 ADJUSTMENT OF THE LEFT SLIDER RECOMMENDED (SELECT CLOSED) 

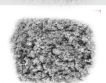
WINTER Shut-Off (Orange color)

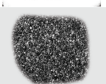
Please note this chart is a guide only. Due to variations in the spreading characteristics of materials, accurate calibration should be carried out by the operator for each different material being applied.

	SHARP/COARSE SAND	 FULL OR REDUCED WIDTH SLIDER OPTION RECOMMENDED 
	FLOWABLE SAND / SOIL MIX	 FULL SLIDER WIDTH USE RECOMMENDED 
	COARSE MARINE SALT	 FULL OR REDUCED WIDTH SLIDER OPTION RECOMMENDED 
	ROCK SALT	 FULL SLIDER WIDTH USE RECOMMENDED 
	GRIT MATERIALS	 FULL SLIDER WIDTH USE RECOMMENDED 

WWW.THEFOUNTAINHEADGROUP.COM

The Fountainhead Group, Inc. is not responsible for misapplication due to incorrect use or incorrect calibration of SMITH® Spreaders. For calibration information please refer to "How to Calibrate" section of the manual prior to initial use.

SMITH® SB80SL SPARE PARTS

Item	Part Number	Description
A	186241	Hardware Pack, CRP035, 80/80ST/80SL
B	186242	Bushing Pack, CRP036, 80/80ST/80SL
C	186243	Pipe Axle, CR3006, 80/80ST/80SL
D	186262	Upper - Rod, C2504, 80/80SL
E	186245	Lower Rod + R pin, CRP030, 80/80ST/80SL
F	186246	Hopper Support SS, CR3010-SS, 80/ST/SL
G	186263	Back Frame Stainless Steel, C2802, SB-80SL
H	186264	Loop Handle Stainless Steel, C2801, SB-80SL
J	186265	Control Unit, CRP006, 80/80SL
K	186251	Spider Agitator, CRP008, 80/80ST/80SL
L	186253	SB80ST Hopper, CRP037, 80/80ST/80SL
M	186255	Impeller + U Pin, CRP031, 80/80ST/80SL
N	186256	Gearbox + U Pin, CRP032, 80/80ST/80SL
O	186257	Summer Plate, CRP9005, 80/80ST/80SL
P	186258	Winter Plate, C2001, 80/80ST/80SL/65
Q	186259	Large Pneumatic Wheel, CRP047, 80/80ST/80SL
R	186266	Raincover , CW3020, SB-80SL
Optional Accessories		
S	N/A	3 - Side Winter Deflector Kit

NOTICE: EXPLODED VIEW DRAWING ON NEXT PAGE.

SMITH® SB80SL SPARE PARTS MODEL

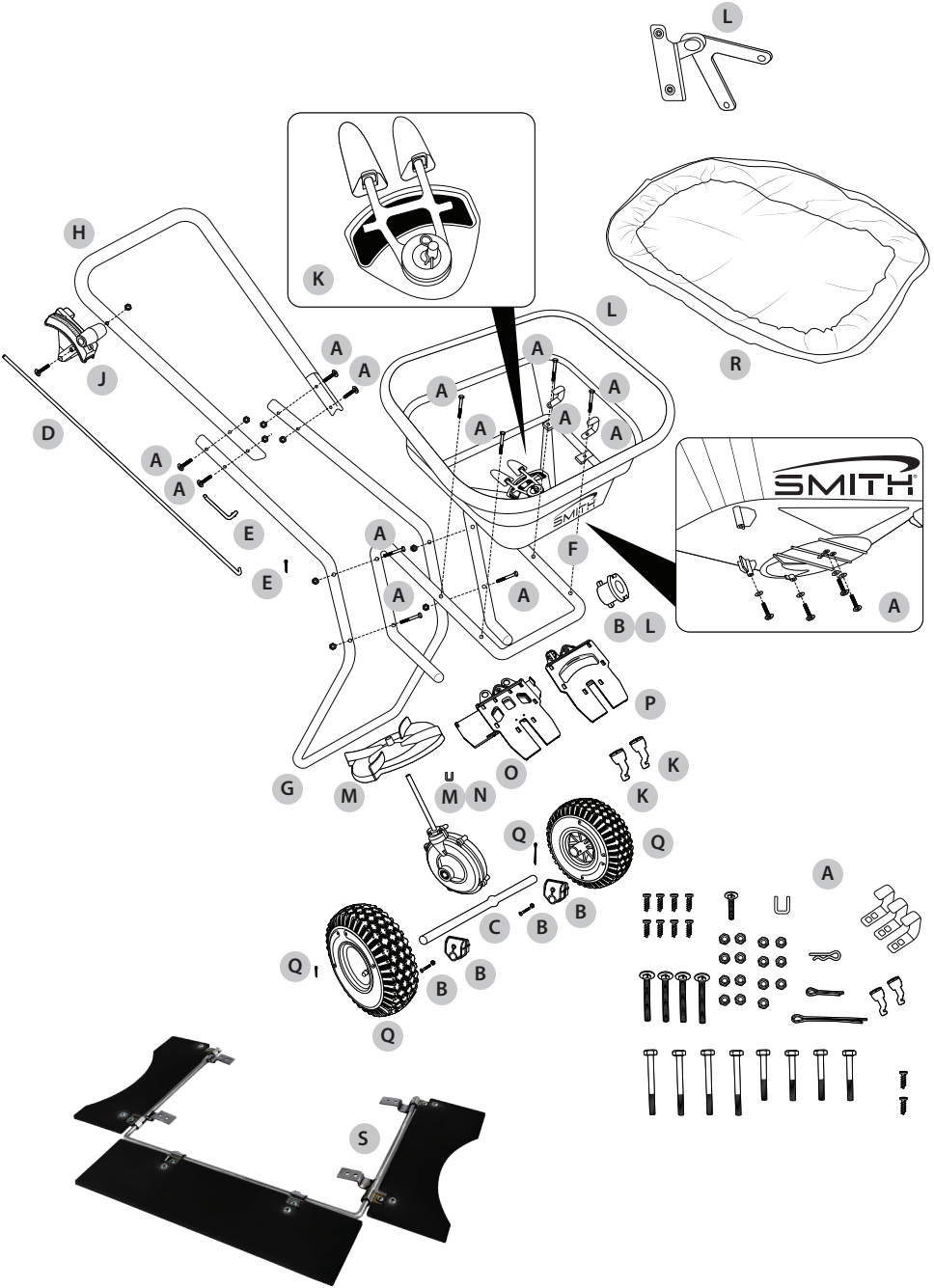

WARRANTY STATEMENT

1-Year Limited Warranty

This limited warranty gives you, the original product purchaser, specific legal rights. You may also have other rights, which vary from state to state.

The Fountainhead Group, Inc. (FGI) warrants to the original product purchaser, that each product will be free from defects in material and workmanship, under normal use and conditions, for a period of one (1) year from the date of purchase. FGI makes no other express warranties, and all implied warranties, including fitness and merchantability, are limited to one (1) year from the date of purchase.

If the product fails to function as intended, call our customer support hotline at +1-800-311-9903 or email info@thefgi.com. Within the warranty period, FGI will repair or replace any part found to be defective upon our examination. FGI reserves the right to require the return of the defective product with the proof of purchase to establish a claim under this warranty. The warranty period is not extended if we repair or replace the product. All shipping expenses will be covered by the customer.

This limited warranty does not cover any damage or defect resulting from transportation, storage, maintenance, improper use, negligence, accident, normal wear, alterations, or operation or any other activity or action which is not in accordance with the instruction manual. Any parts that are deemed wearable parts are not part of the limited warranty.

In no event shall FGI be liable for any incidental, special, consequential or punitive damages, or for any attorney fees, expenses, losses or delays alleged to be as a consequence of any damage to, failure of, or inadequate product training, but not limited to, any claims for loss of profits.

