

VP OAU W VCE POC OAUU WUE OAUUUU O VCE YA OZUUT CE/OP K OUAUV OWS OCB O O S U O A U A  
 UVP O U U A U A W O A U A U A W U U U O U A U V P O A P O B A U A O C E U Y A I W A P O A V O P V A U U A P O P A P O I A T C E / O U O S A O S A O O O A  
 W P S O U A Y U Q V O P A O U P O C P V A U A W U A V O V C E O A J U T A B U W V C E P O C O A U U W U E O A B W P U U O O A U O U U O U P V C B / Q C E

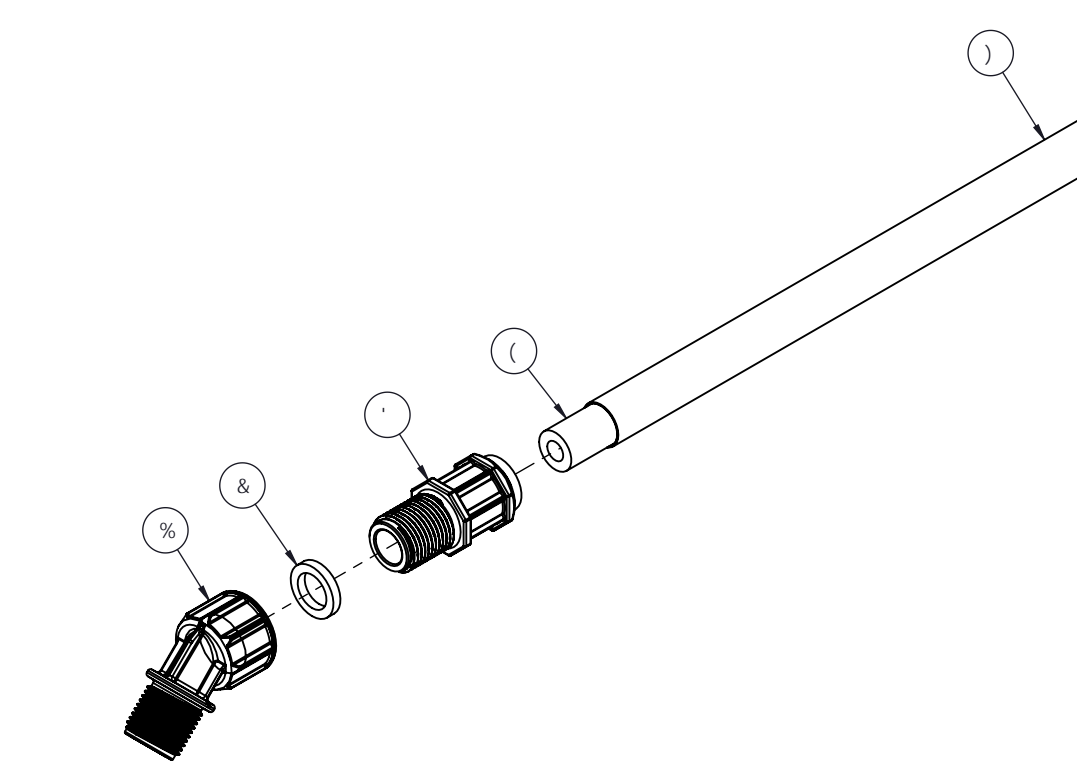
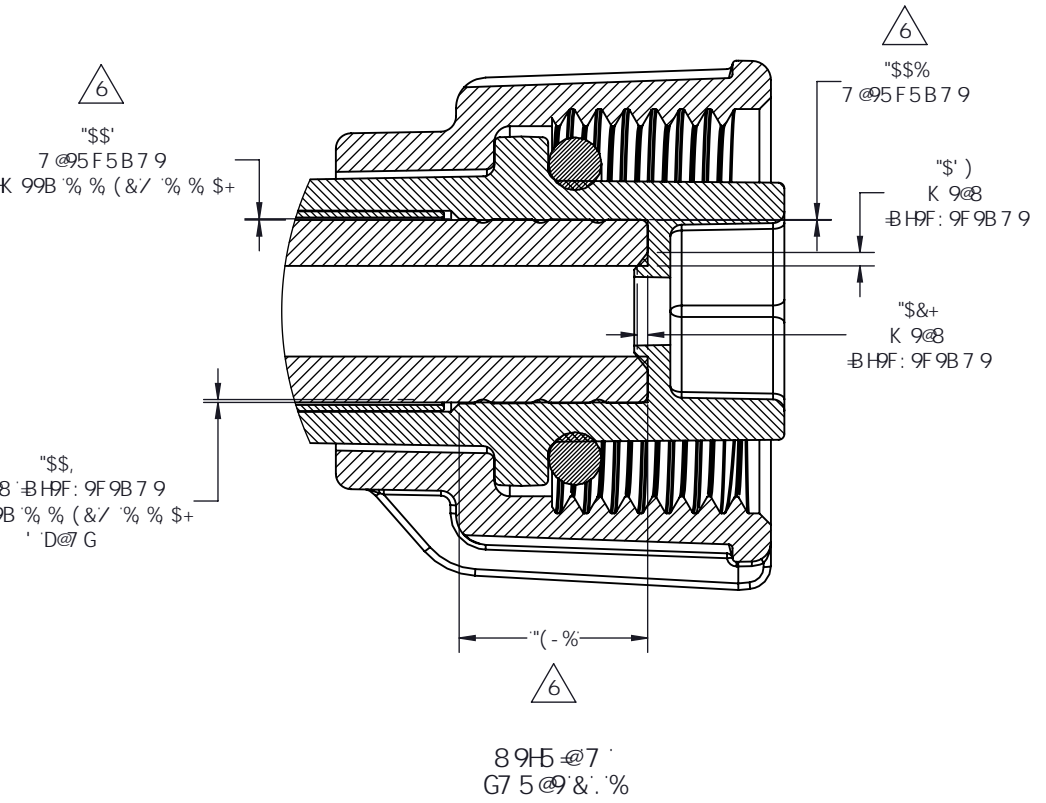
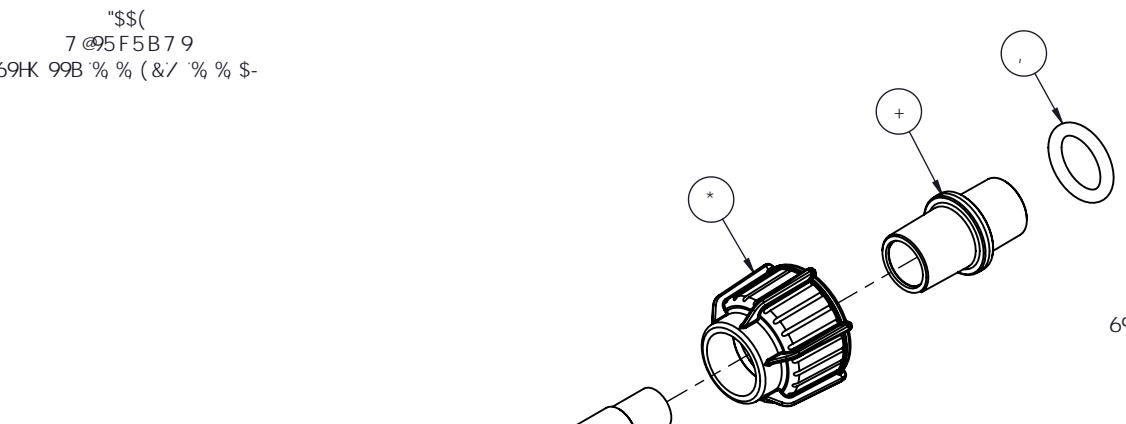
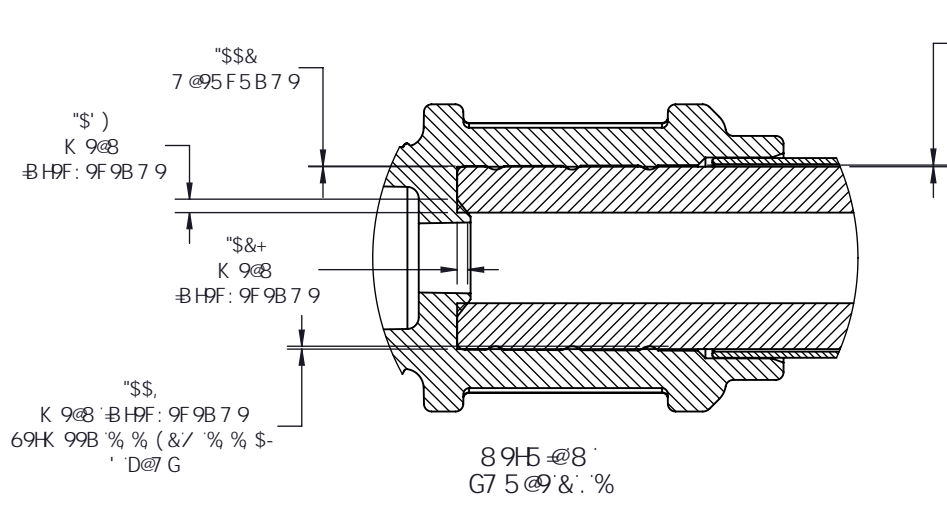
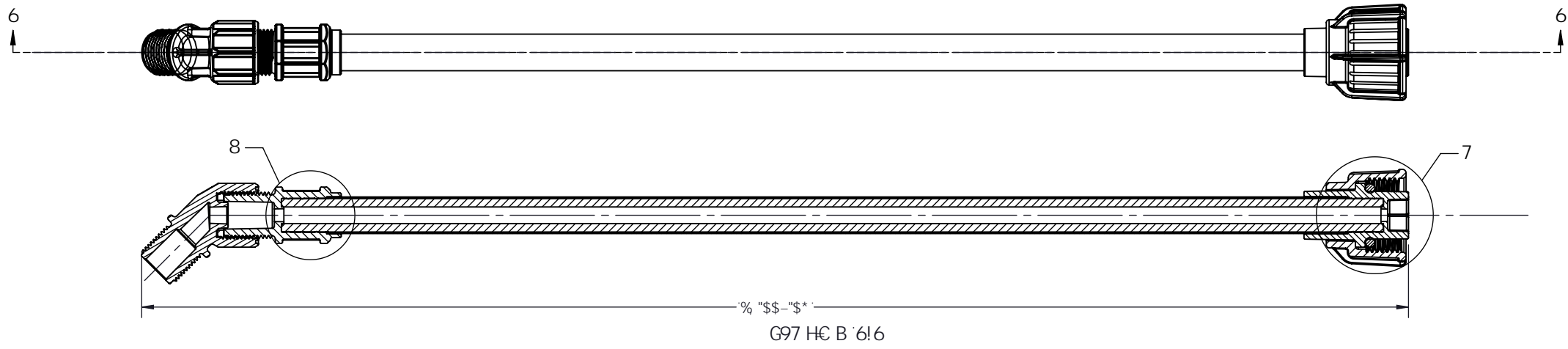

#PA BC	D5FHBC	8 9 G 7 F D H C B	E H M
%	% % %	5 8 5 D H F Z 5 B ; @ 8 Z K 5 B 8 # B C M N @ Z G A =	%
&	% % % &	: @ H G 9 5 @ B C N N @ Z J + C B	%
'	% % \$ -	5 8 5 D H F Z K 5 B 8 # B C M N @ Z G A =	%
(	% % ( &	H 6 9 Z % " K 5 B 8 ' 5 G G M Z D D Z G A =	%
)	% ( ' , %	H 6 9 Z % " K 5 B 8 ' G G Z G A =	%
*	% % % %	K 5 B 8 B I H Z G A =	%
+	% % \$ +	5 8 5 D H F Z K 5 B 8 # J 5 @ 9 6 C 8 M Z G A =	%
,	% % % \$	C I F B ; Z J H C B Z K 5 B 8 Z G A =	%

ó	U O P A O S O A U O A O O O A U A I F I E A H A U V C S O K E F O S O C E Y E Y A E E G O S O C E I B E E A O S O C E U E Y A E E A O S O C E U E B A I O A E J F A O A O P U A P	CE	U O S O C E U O U C E Y @ O	U O X E	O O U O U A W A P

**CF AC @ 98 7 CADCB9 BHG CB @**

FEU OZOUAUA OAOOA UOSA  
 % ( ' , &  
 UUAUUA S S A U E V A O U T O V Y E

GET USO OOUO PAT WUNAOOEJUUXOO  
 MOYA : OPOOOUO OAUUUAU  
 USO OUPUVUWONVPE

8 C B C H G 7 5 @ D F B H  
 VP S O U A U V P O U Y @ O U U O O Z O O  
 O T O P U A P U A E U O B A B O P O U  
 V U S O C E P O O U  
 E Y A P E E F  
 E Y A P E E E F  
 E Y Y A P E E E E I  
 O P O S O U A A A F B \*  
 O P O P K /  
 Y Y Y A A O U O A O S A  
 V U A U W C S O Y

T O S O U C S K  
 U O O A O O A W A S A O U C E Y @ O U

UAEVAPWT OOUK  
 % ( ' , &

UAEVAPWT OOUK  
 % ( ' , &

F9J.  
 6  
 UPOO/FAUO/E